

eclipse II plus

**High Frequency
Opportunity, Fast, or
Conventional Charging**



The Industry Standard For All Your Charging Needs

- ⚡ No need for multiple charge types, Eclipse II works in Opportunity, Fast, or Conventional mode**
- ⚡ Reduce energy costs with the AC characteristics of the Eclipse II Plus**
- ⚡ Energy efficiency as high as 93% reduces energy costs**
- ⚡ The small and light Eclipse II Plus can hang on a wall or sit on a shelf, eliminating the need to buy a stand**
- ⚡ Easy access to components for service or maintenance**
- ⚡ Wireless fleet management system**
- ⚡ Available in 480 VAC only and 480/600 VAC**
- ⚡ UL and cUL listed**

AMETEK
PRESTOLITE POWER



Made in America

eclipse II plus



Inside View



Side View

Side panel is removable for easy access to components



Eclipse II Plus

The Eclipse II Plus is the most adaptive charging solution on the market, and it maintains the same quality you've come to expect from Ametek. The opportunity charging function will sustain the battery between 30% and 80% state of charge via short, opportunistic charges and is able to fully charge your battery in 6 hours or less. Conventional charging mode recharges any 100% drained lead-acid battery within the charger's rated capacity, flooded or sealed, in 8 hours or less.

Advanced IGBT high frequency power conversion circuitry supplies efficient, reliable service in all modes and supports the fast charging capability of the Eclipse II Plus for when you need your battery available as soon as possible. Small size allows you to use your existing charging configuration, no need to make more space. No matter the battery age, battery type, or electrolyte temperature, the intelligent monitoring system of the Eclipse II Plus enables it to provide optimum charge with minimal temperature rise and to complete the charging cycle at the proper current.

Low Cost Efficient Operation

The high power demands of opportunity chargers require an energy efficient design. The advanced high frequency design of the Eclipse II Plus is extremely efficient at 93%, converting AC power to usable DC power with the minimum possible impact on the utility grid. The .95 power factor minimizes AC amp draw and thereby reduces installation costs.

EC2000 Control

The new EC2000 control is nearly identical in functionality and programmability to AMETEK's popular UC2000 used in the Ultra product line. With a 40 character, alphanumeric LCD display, easy to read information is always available to follow the chargers status. In addition, 4 bright LEDs provide charge status at a glance and the sealed membrane keypad allows for easy customer interface.

Energy Saving Features

Further enhance energy savings by utilizing the EC2000's programmable start modes. Using the **Delayed** or **Time-of-Day** start modes of the EC2000 to charge your batteries during off-peak hours can yield up to 50% in additional energy cost saving. The EC2000 also offers **Time-of-Day Block-Out** to lower utility bills and reduce peak demand by blocking out a period of charging time on one or more chargers.

Minimize Hydrogen Gas Emissions

The No-Gassing feature of the Eclipse II Plus allows a programmable time to be set so that should the charger reach the gassing portion of the charge cycle within the set time, the charger would stop charging until the set time has elapsed. Only at this point would the charger continue to charge and take the battery to charge complete.

Automatic or Manual Equalize Operation

All Eclipse II Plus chargers are shipped with Automatic Equalize enabled to ensure that your batteries routinely receive an equalize charge of three hours beyond the normal DV/DT charger termination. Auto Equalize can be set for one of two options, Number of Cycles, or Day of Week.

When any automatic equalize function is selected, the equalize button on the keyboard is disabled to prevent unnecessary equalize charges. The ability to automatically equalize batteries provides an exact schedule of equalize charges for better battery maintenance and longer life.

Control Equalization Cycles

When an AMETEK BID is attached to the battery, it tracks and records completed charge cycles. When the battery is connected to the charger, the Eclipse II Plus reads the BID information to determine how many charge cycles have been completed since it was last equalized. When the number of completed cycles matches the user selected equalize interval, the charger will equalize that battery. This ensures that each battery is equalized at the intervals selected by the customer regardless of which charger is connected.

Battery Cool Down

Battery cool down allows the battery to cool down before use, which allows for increased control of battery rotation, resulting in increased battery efficiency and longer life. Battery cool down can be programmed from the EC2000 keypad from 0-8 hours in one hour increments. After the recharge is complete, the display will read "battery cool down" until the predetermined cool down period has ended, at which time the charge complete LED is illuminated.

Regulation

The Eclipse II Plus is designed to hold the finish voltage rate to within +/-1% and the finish current to within +/-2% over a wide range of line voltage variations.

High Frequency Opportunity, Fast, or Conventional Charging

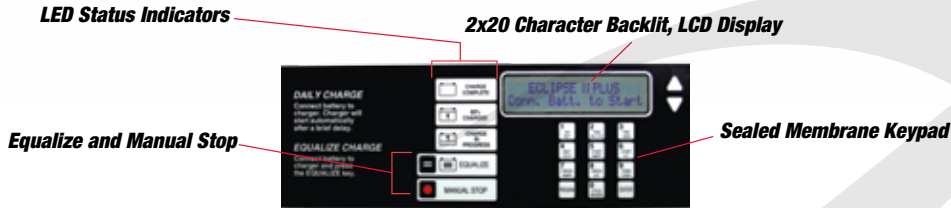

Mounting Options

Flexible cabinet design allows charger to be mounted on a shelf or the wall without additional brackets. The legs are simply removed from the bottom of the charger and bolted to the rear panel to convert the charger from shelf mounting to wall mounting. Chargers can be stacked up to three high.

Quiet Fan Cooling

The Eclipse II Plus utilizes an advanced fan design to cool the electronics, extending life while providing low sound levels for quiet operation.

3 Year Full Warranty

Repair costs are minimized through a 3 year full warranty for the original purchaser. Warranty covers labor, travel, and parts replacement.

Prevent Overcharging

Back-up timers protect your batteries from overcharging by shutting the charger off in the event that the battery does not reach 80% charged in 9 hours, or does not reach charge complete within 4 hours of reaching the 80% charged point. The charger also monitors the ampere hours returned and if the ampere hours returned exceed the rated ampere hour capacity by 125%, the charger will shutdown, protecting your battery from harmful overcharging. (150% on equalize cycles.)

Charge Cycle Archive

The Eclipse II Plus will collect and save 21 items of charge cycle information for the last 500 charge cycles. This valuable information can then be reviewed manually from the front panel, or it can also be downloaded wirelessly using our Datalink² system.

Operating Modes

Multi-cell: automatically matches output voltage to battery

Fixed-cell: set for specific battery voltage, rejects others

BID mode: information programmed in BID determines charger operation

Timer Start: operated as a manual timer for maintenance and shop charging

Refresh Charge

Start off the week with fully charged batteries. Anytime the battery is left plugged into the charger for an extended time, such as over a long weekend, the charger will restart automatically and top off the battery to ensure your trucks are running at peak performance.

Monitor Battery and Charger Operation

With no spare batteries, it's important to know that your batteries are being properly charged and maintained. The AMETEK BID with Amp-Hour Accumulator measures and records electrolyte temperature and accumulated ampere-hours, both charged and discharged. The accumulated ampere-hours are essential to support battery warranty and to predict battery end of life. The functionality of the Eclipse II Plus charger can be greatly enhanced through the addition of the optional Battery Identification Module, BID. The BID is programmed with battery information including rated AH capacity, rated voltage, battery type, and start rate for opportunity charging.

Batteries with BIDs will be automatically recognized by the charger, allowing the charger to charge at the proper voltage and current levels for the type of battery connected. The BID eliminates any manual charger settings.

Wireless Fleet Management System

The Eclipse II Plus has the Datalink² wireless module built-in. Datalink² gives you the opportunity to monitor battery usage and identify bad situations before they become problems that lead to down time.

Datalink² greatly enhances the ability to collect charge and discharge data from the charger. The transfer of data occurs wirelessly utilizing our proprietary wireless network in combination with a powerful transceiver. Typical communication range is 1,500 ft in a normal operating environment and with communication between chargers, this range is doubled to a 3,000 ft radius. The actual range in your facility can vary greatly based on numerous factors. It is not necessary for the system to be integrated into the customer's network.

Battery Identification Module



The functionality of the Eclipse II Plus charger can be greatly enhanced through the addition of the optional Battery Identification Module, BID. The BID is

programmed with battery information including rated AH capacity, rated voltage, battery type and more.



BID with Ampere Hour Accumulator

When equipped, a battery with an ampere-hour accumulator BID will transmit to the

EC2000 control, the updated AH data. The accumulated AHs for both charge and discharge cycles are stored in the BID along with the lifetime average battery temperature, and is readable from the EC2000 control and through the Datalink² System.

Dimensions

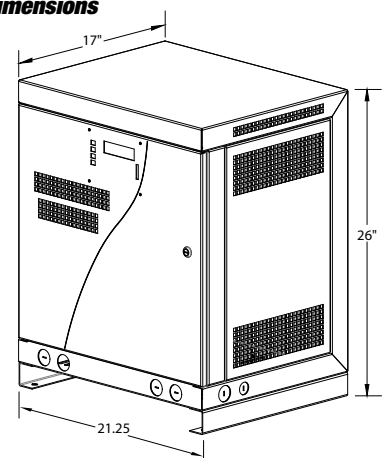

ECLIPSE II PLUS 480VAC ONLY MODELS

Number Battery Cells	Model Number	Battery Amp-Hour Capacity for 8 Hrs.	DC Output Amps	Phase	AC Input Amps at 480 VAC 60 HZ-3 ph	Approx. Weight (lbs.)
Three Phase 100%						
6,9,12	550EC3-12SP	550	138	3	5.5	106
6,9,12	680EC3-12SP	680	170	3	6.8	106
6,9,12	800EC3-12SP	800	200	3	8.0	110
6,9,12	900EC3-12SP	900	225	3	9.0	110
6,9,12	1050EC3F-12SP***	1050	263	3	10.5	110
6,9,12,18	550EC3-18SP	550	138	3	8.3	106
6,9,12,18	680EC3-18SP	680	170	3	10.2	106
6,9,12,18	800EC3-18SP	800	200	3	12.0	110
6,9,12,18	900EC3-18SP	900	225	3	13.5	110
6,9,12,18	1050EC3F-18SP***	1050	263	3	15.8	110
6,9,12,18	1200EC3F-18SP***	1200	300	3	18.0	110
6,9,12,18	1360EC3-18DP	1360	340	3	20.4	134
6,9,12,18	1680EC3-18DP**	1680	420	3	25.2	154
6,9,12,18,24	550EC3-24SP	550	138	3	11.0	106
6,9,12,18,24	680EC3-24SP	680	170	3	13.6	106
6,9,12,18,24	800EC3F-24SP***	800	200	3	16.0	110
6,9,12,18,24	900EC3F-24SP***	900	225	3	18.0	110
6,9,12,18,24	1050EC3-24DP	1050	263	3	21.0	134
6,9,12,18,24	1200EC3-24DP	1200	300	3	24.0	134
6,9,12,18,24	1260EC3-24DP	1260	315	3	25.2	140
6,9,12,18,24,36,40*	375EC3-40SP	375	94	3	12.5	101
6,9,12,18,24,36,40*	550EC3F-40SP***	550	138	3	18.4	110
6,9,12,18,24,36,40*	680EC3-40DP	680	170	3	22.7	134
6,9,12,18,24,36,40*	750EC3-40DP	750	188	3	25.0	140

ECLIPSE II PLUS 480/600VAC MODELS

Number Battery Cells	Model Number	Battery Amp-Hour Capacity for 8 Hrs.	DC Output Amps	Phase	AC Input Amps 480 VAC60 HZ-3 ph	AC Input Amps 600 VAC60 HZ-3 ph	Approx. Weight (lbs.)
Three Phase 100%							
6,9,12	550EC3-12SPC	550	138	3	5.5	4.4	106
6,9,12	680EC3-12SPC	680	170	3	6.8	5.5	106
6,9,12	800EC3-12SPC	800	200	3	8.0	6.4	110
6,9,12	900EC3-12SPC	900	225	3	9.0	7.3	110
6,9,12	1050EC3F-12SPC***	1050	263	3	10.5	8.2	110
6,9,12,18	550EC3-18SPC	550	138	3	8.3	6.6	106
6,9,12,18	680EC3-18SPC	680	170	3	10.2	8.2	106
6,9,12,18	800EC3-18SPC	800	200	3	12.0	9.7	110
6,9,12,18	900EC3-18SPC	900	225	3	13.5	10.8	110
6,9,12,18	1050EC3F-18SPC***	1050	263	3	15.8	12.6	110
6,9,12,18	1200EC3F-18SPC***	1200	300	3	18.0	14.4	110
6,9,12,18	1360EC3-18DPC	1360	340	3	20.4	16.3	134
6,9,12,18	1680EC3-18DPC**	1680	420	3	25.2	20.2	154
6,9,12,18,24	550EC3-24SPC	550	138	3	11.0	8.7	106
6,9,12,18,24	680EC3-24SPC	680	170	3	13.6	11.0	106
6,9,12,18,24	800EC3F-24SPC***	800	200	3	16.0	12.8	110
6,9,12,18,24	900EC3F-24SPC***	900	225	3	18.0	14.4	110
6,9,12,18,24	1050EC3-24DPC	1050	263	3	21.0	16.8	134
6,9,12,18,24	1200EC3-24DPC	1200	300	3	24.0	19.2	134
6,9,12,18,24	1260EC3-24DPC	1260	315	3	25.2	20.2	140
6,9,12,18,24,36,40*	375EC3-40SPC	375	94	3	12.5	10.0	101
6,9,12,18,24,36,40*	550EC3F-40SPC***	550	138	3	18.4	14.7	110
6,9,12,18,24,36,40*	680EC3-40DPC	680	170	3	22.7	18.2	134
6,9,12,18,24,36,40*	750EC3-40DPC	750	188	3	25.0	20.0	140

* Control does not auto select between 36 and 40 cell ** Arcless disconnect and dual cables REQUIRED.

*** Models with "F" come equipped with additional fan assembly on higher current, single engine units.



Distributed By:

Manufactured by **AMETEK** PRESTOLITE POWER

Phone: 800.367.2002 • Fax: 800.654.4024
www.prestolitepower.com

Because we continually improve our products, specifications are subject to change without notice.
©2016, AMETEK, Inc. Prestolite Power, Troy, Ohio
Data Sheet: 1607 05/16 5M Printed in U.S.A.
Replaces 05/13

